

OFFICIAL WARWICK AMP OWNER MANUAL

ENGLISH



CCL

SAFETY HINTS

- Read these instructions
- Keep these instructions
- Heed all warnings
- Follow these instructions



Caution: To reduce the risk of electrical shock, do not remove the cover. Or expose this appliance to rain or moisture. No user serviceable parts inside; refer servicing to qualified personnel.

Apparatus shall not be exposed to dripping or splashing and no objects filled with liquids, such as vases shall be placed on the apparatus.



This symbol, wherever it appears, alerts you to the presence of uninsulated dangerous voltage inside the enclosure--voltage that may be sufficient to constitute risk of shock.



This symbol, wherever it appears, alerts you to important operating and maintenance instructions in the accompanying literature. Read the manual.



Use only with cart, stand, tripod, bracket or table specified by the manufacture, or cart/apparatus combination to avoid injury from tip-over.

Congratulations on the purchase of the new Warwick combo. Please read through these instructions before connecting and operating the device. If you keep to the guidelines set out in this manual, you will soon be able to appreciate the quality of this new Warwick amplifier. Please keep this instruction booklet handy in case you need to consult it again. Please send the PASSPORT to the address indicated therein.

RECOMMENDATIONS

The following recommendations are designed to ensure that the device always functions reliably:

- Never open the casing! To do so would expose you to the risk of an electric shock. Should repairs prove necessary, leave them to qualified service personnel.
- Avoid dust and high moisture levels, direct sunlight and extremely high or low temperature.
- Safeguard the device from excessive vibration. Always place the unit on a stable and horizontal surface.
- See to adequate ventilation. The device should not be placed on soft surfaces (carpet, cushions, etc.). When mounting it in a rack, make sure that the rear and lateral cooling vents remain unobstructed.
- Avoid leaving the unit near radiators or other objects producing heat.
- Internal components should only be adjusted or cleaned by qualified service technicians. Ensure no object or liquid penetrates the device through its cooling vents.
- When replacing a fuse make sure you fit in one of identical value!

Have the device examined by a qualified service technician in the following cases:

- the mains lead or mains switch have been damaged,
- objects or liquids have penetrated the device,
- it has been exposed to excessive moisture,
- malfunctions or abnormal operating conditions have occurred,
- the device has been dropped or the casing damaged.

HINTS

- This apparatus shall not be exposed dripping or splashing and that no objects filled with liquids, such as vases, shall be placed on the apparatus.
- This apparatus should be connected to a MAINS socket outlet with a protective earthing connection.
- Mains plug or appliance connector shall be used as the disconnect device, so mains plug or appliance connector should always remain readily operable.
- If the apparatus shows any malfunction, immediately disconnect the main power cord from the mains socket.
- Do only operate effects pedals in-between the instrument and the amplifier, as these devices are not designed for the supplied load of an effects loop.
- Remove the plug whenever changing a fuse.
- Only ever replace a fuse with another of the same type. Never bridge defective fuses.
- Make sure the top and bottom of the device are properly ventilated and that the vents are not blocked.
- Do not subject the device to excessive vibration or hard jolts as these could damage the device.
- Don't undertake repairs yourself.
- Only allow the case to be opened by qualified personnel. (Remove the plug).
- Repairs should only be undertaken by qualified personnel.

SHOULD YOU FIND YOURSELF ONE DAY WONDERING: "WHY IS THERE NO SOUND COMING OUT?"

please check:

- all stub cables,
- all connections of these cables

and proceed anew by following the guidelines of the chapter GETTING STARTED. Possibly the problem reveals to be an operational error.

PROTECTIVE CIRCUITS

Your new Warwick amplifier is equipped with a series of circuits to prevent it from destruction in case of inadequate operating conditions:

- Power-up delay:** When the unit is switched on, the **SPEAKER OUT** sockets are activated with a slight delay to protect the loudspeakers.
- Short-circuit:** In the event of a short-circuit at the power amp outputs, this feature prevents the output stage transistors from destruction by quickly reducing current.
- Direct current (DC):** This circuit continuously monitors the power amp output for direct current and protects the loudspeakers from overload should a transistor burn out.
- HF oscillation:** By switching the power amp off, this safety feature prevents from damages that could be caused by frequencies in excess of 20 kHz (feedback, etc.).
- Excessive temperatures:** Should the temperature-regulated fan cooler prove to be insufficient in extreme conditions, this circuit protects the output stage transistors from destruction by switching the device off.
- Limiter:** The combos CL and CCL are equipped with a limiter, that limits the poweramp outputs to 200 watts (CL), 300 watts (CCL) in order to protect the loudspeakers.
- Note:** You can recognise that one of these circuits has been activated as a result of a fault, when the **MUTE LED** glows continuously even though you have not selected the MUTE mode. In case of a short-circuit please check the speaker cable. The amplifier must then be switched off and on again, to get back into playing mode after having removed the short-circuit. In any other situation the amplifier switches automatically back to playing mode as soon as it detects the fault has disappeared (e.g. the amplifier has overheated and cooled down again).

GETTING STARTED

1. Make sure that loudspeakers capable of sustaining the load of a bass signal are connected to the **SPEAKER OUT** sockets, resp. the speaker unit should be linked to the **SPEAKER OUT** at the combos.
2. Check that the mains supply has been plugged in and that all external (effects) units possibly used are correctly connected and operational.
3. Set the **MASTER** control to zero.
4. Plug your bass guitar into the amplifier's **INPUT** with a shielded line-cable.
5. Press the **POWER** switch to turn the device on.
6. Switch **MUTE** off and the red LED will extinguish.
7. Switch the **LIMITER** off (the 2-colored LED will extinguish, CL, CCL).
8. Turn all volume controls of your bass guitar on to their maximum.
9. Adjust the **GAIN** control until the (loudly) played bass signal flashes the clip LED.
10. Set the **MASTER** control to the volume you wish to play at.
11. Adjust the sound that you wish with the controls and switches described in the respective chapters **FRONT PANEL CONTROLS**.
12. If necessary readjust **GAIN**.
13. Should you seek for a peak limited sound, activate the **LIMITER** (LED green) and fix its threshold (LED shifts to red) with **GAIN**.

FRONT PANEL CONTROLS

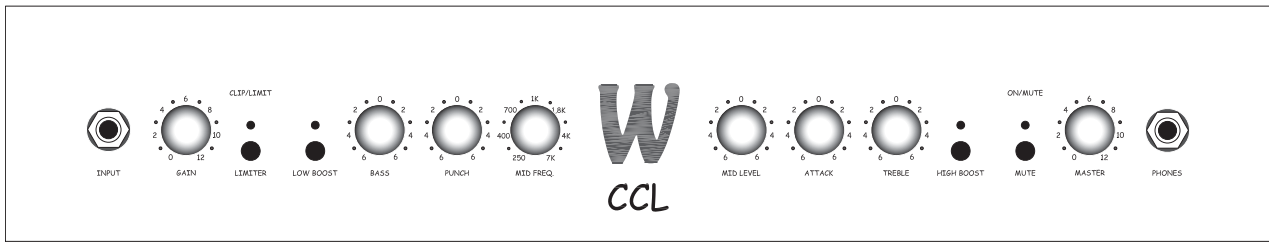

- INPUT** socket to plug in a bass guitar.
- GAIN** control + CLIP/LIMIT LED to adjust the input level.
- LIMITER** switch + 2-colored CLIP/LIMIT LED to compress the signal within the preamp.
- LOW BOOST** switch + LED to boost low end.
- BASS** control to boost/cut deep frequencies.
- PUNCH** control for boosting/cutting deep mids.
- MID FREQ.** control to determine a frequency.
- MID LEVEL** control to boost/cut the frequency adjusted with the MID FREQ. control.
- ATTACK** control for boosting/cutting high mids.
- TREBLE** control to boost/cut high frequencies.
- HIGH BOOST** switch + LED to boost treble.
- MUTE** switch + ON/MUTE LED cuts the signal from all outputs, except from the PHONES socket, and activates the TUNER output (rear panel). In case of signal flow at the power section (Input or Effects Return), there might appear a popping noise when MUTE is pressed. To avoid this, mute your strings or have effects like delays muted when pressing the MUTE button.
- MASTER** control determines the mains level.
- PHONES** socket for connecting a headphone (min 200 Ω)

REAR PANEL

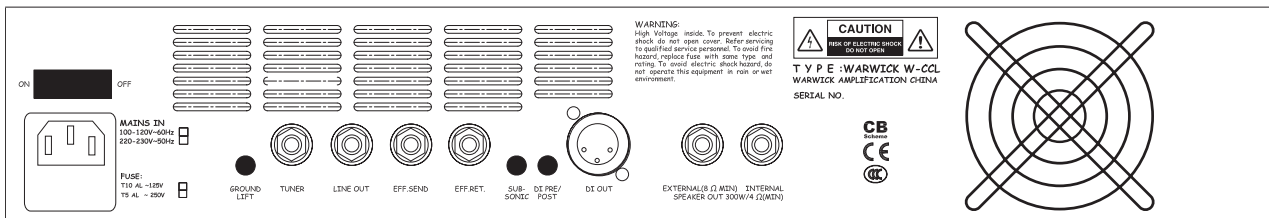

- MAINS IN AC POWER** Terminal with integrated fuse compartment for connecting the amplifier to the current network.
- GROUND LIFT** switch for turning the amplifier on and off.
- TUNER OUT** socket isolates the earth connection from the ground of signal. Should several devices be simultaneously connected to earth by the same conductor as well as via line connections, a so called hum loop might appear. In this case operate GROUND LIFT to eliminate the current hum (when pressed).
- LINE OUT** socket for the connection of a tuner. When MUTE mode is activated, the unmodified bass signal is retained here.
- EFF. LOOP** socket allows to connect additional power amplifiers or active cabinets. for the insertion of effects units. Connect SEND with the input and RETURN with the output of the effects device.
- DI OUT** symmetrical output for supplying a stage or studio mixing console.
- DI PRE/POST** switches the signal lying at the DI OUT socket, PRE (pressed) unmodified bass signal, or POST (unpressed) bass signal treated by tone controls and possibly by connected effects devices.
- SUBSONIC** switch for cutting low end from the poweramp.
- SPEAKER OUT** socket for connecting the loudspeaker and the tweeter. CCL-8ND and CCL-210ND are equipped with a second SPEAKER OUT socket for connecting an external speaker cabinet, min. 8 ohms.

TECHNICAL DATA

	Take 12	Sweet 15	CL	CCL	SUB III
Input	25 mV	25 mV	25 mV	25 mV	25 mV
Preamp CH 1	transistor active controlled	transistor active controlled	transistor active controlled	transistor active controlled	none
Preamp CH 2	n/a	n/a	n/a	n/a	n/a
Poweramp	fan cooled (non permanent)	fan cooled (non permanent)	fan cooled (non permanent)	fan cooled (non permanent)	fan cooled (non permanent)
CH 1 Equalizer	bass, mid low, mid high, treble controls	bass, mid low, mid high, treble controls, low boost/high boost switches	bass, param.mids with freq. and level controls, treble, low boost, high boost switches, Dyn. control with switchable limiter	bass, punch, param. mids with freq. and level controls, attack, treble, low boost and high boost switches. Dyn. control with switchable limiter	
CH 2 Equalizer	n/a	n/a	n/a	n/a	n/a
Headphone	min 200 Ω	min 200 Ω	min 200 Ω	min 200 Ω	none
Direct Out	none	none	0 dB, 600 Ω	0 dB, 600 Ω	none
Effects Loops	mono serial send 0 dBu, 600 Ω return 0 dBu, 10 k Ω	mono serial send 0 dBu, 600 Ω return 0 dBu, 10 k Ω	mono serial send 0 dBu, 600 Ω return 0 dBu, 10 k Ω	mono serial send 0 dBu, 600 Ω return 0 dBu, 10 k Ω	none
Switches	Horn Off	Horn Off	ground lift. DI pre/post	ground lift, DI pre/post	-3 dB pad
Rear Control	none	none	Horn Attenuator	Horn Attenuator	none
Footswitch Jack	n/a	n/a	n/a	n/a	n/a
Nominal Power	80W / 4 Ω jack	150W / 4 Ω jack	200W / 4 Ω jack	300W / 4 Ω jack	300W
THD	<0.1%	<0.1%	<0.1%	<0.1%	<0.1%
Weight (kg)	16.5	25	20	27.75	24.2
Dimensions (mm)	395 x 555 x 325	530 x 640 x 340	441 x 396 x 460	531 x 484 x 600	440 x 480 x 600

CIRCUIT DIAGRAM

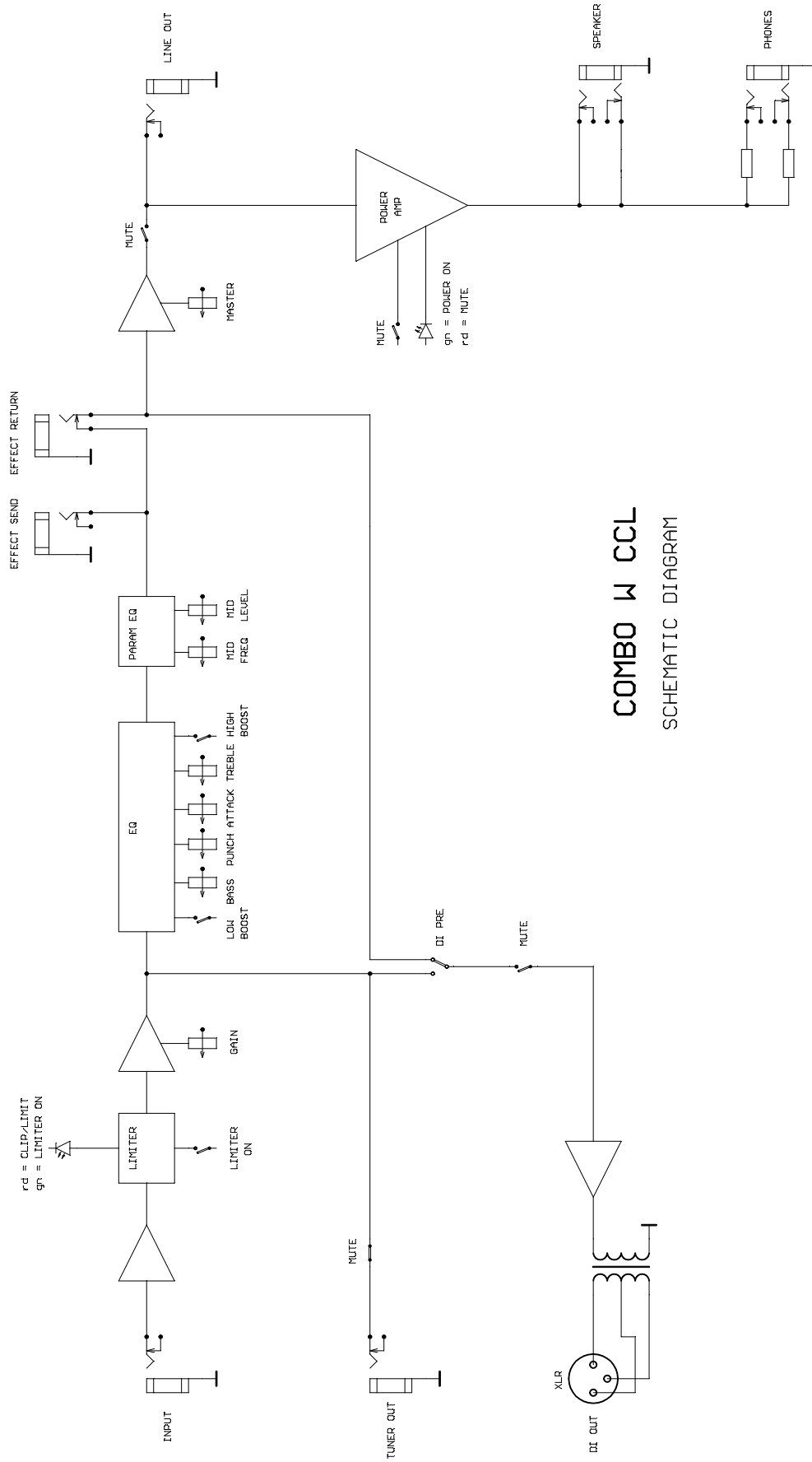

COMBO W CCL
SCHEMATIC DIAGRAM

Headquarters: Warwick GmbH&Co.Music Equipment KG • Gewerbegebiet Wohlhausen • 08258 Markneukirchen/Germany • E-Mail: info@warwick.de
Branch China: Warwick Music Equipment (Shanghai) Ltd., Co. • Shanghai Waigaoqiao Free Trade Zone • Shanghai 200131/P.R.China • E-Mail: info@warwick.cn
Branch UK: Warwick Music Equipment Trading (Manchester UK) Ltd. • 75 Bridge Street • Manchester M3 2RH / Great Britain • E-Mail: info@warwickbass.co.uk
Branch Switzerland: Warwick Music Equipment Trading (Zurich) GmbH • Kriesbachstrasse 30 • 8600 Dübendorf / Switzerland • E-Mail: info@warwick.ch
Branch CZ: Warwick Music Equipment Trading (Praha CZ) s.r.o. • Spálená 23/93 • 11000 Praha 1 / Czech Republik • E-Mail: info@warwick.cz

Visit us on the World Wide Web: <http://www.warwick.de>

